

# Nonprestressed Bonded Reinforcement in Post-Tensioned Building Design

By Bijan O. Aalami<sup>1</sup>

Reviewed by: Randall F. Cailor<sup>2</sup>, PE

## SUMMARY

This Technical Note describes the bonded reinforcement required to supplement post-tensioning tendons in buildings. It covers both unbonded and bonded (grouted) post-tensioning systems under gravity and lateral (wind and seismic) loading. Using the International Building Code [IBC 2000] as a reference, the Code stipulated minimum requirements and their implementation are explained in detail. This is followed by a discussion of Structural Detailing practices and constructibility requirements. Several numerical examples illustrate the concepts presented.

## 1 - INTRODUCTION

As with conventionally reinforced structures, post-tensioned members must be designed for both serviceability and strength. The design includes a serviceability “stress check” under working conditions and a “strength check” under a factored load (an assumed overload) [Aalami, Kelley, 2001a].

Serviceability design of post-tensioned floor systems includes a check for cracking and deflection under service loads. Cracking is controlled by using a hypothetically calculated “tensile stress” as a guide. This is referred to in the Code as the “computed stress.” The Code requirements for minimum added bonded reinforcement are different for unbonded and bonded systems [Aalami, 1994]. The requirements are discussed below and are discussed further in [ACI 423, 1996; PTI, 1990; Aalami, Bommer 1999].

## 2 - MINIMUM REQUIREMENTS OF THE CODE

This section discusses the minimum requirements for bonded reinforcement given in Chapter 18 of ACI-318 [ACI-318, 1999], as modified by Section 1908 of the IBC.

### 2.1 Construction with Bonded Tendons

In bonded post-tensioning systems, supplemental bonded reinforcement is not required if:

- (i) the post-tensioning meets the stress requirements of the Code under service loading, and
- (ii) the post-tensioning by itself is adequate for the strength requirement.

Hence, it is possible to construct a slab reinforced with grouted tendons and in compliance with the Code, with no nonprestressed reinforcement (top or bottom). Strength requirements during construction and construction sequence should be reviewed carefully when employing this method of construction.

### 2.2 Construction with Unbonded Tendons

For floor systems constructed with unbonded tendons there are minimum requirements for bonded reinforcement. The objective of this minimum reinforcing is crack control under service loads and adequate ductility when a member is overloaded.

The requirements are different, depending on whether the slab is a one- or two-way system. In a one-way system such as a one-way slab and beam system, the members only carry the load in one direction. In a two-way system such as a column-supported slab, the load is carried in both directions. Further discussion of the differences between one- and two-way systems is given in reference [Aalami, 1993b].

#### 2.2.1 Minimum Bonded Reinforcement of Two-Way Systems

The Code requirements for minimum reinforcement are based on the geometry of **tributary** and **span length**, and **design actions** (moment and axial loading) of the **design strip**. These terms are described with the aid of **Figs. 2.2.1-1** through **2.2.1-5**.

**Figure 2.2.1-1** shows the plan of a column-supported floor system. For the purposes of design, the floor slab is divided into **design strips** in two orthogonal directions [Aalami, Bommer, 1999]. **Figure 2.2.1-2** shows the design strips in the X-direction. The design strip is handled differently, depending on whether

<sup>1</sup> Professor Emeritus, San Francisco State University; Principal, ADAPT Corporation, Redwood City, California.

<sup>2</sup> Cailor and Associates, LLC, 4542 Warrior Trail, Lilburn, Georgia, 30047.

the design is being done with the Finite Element Method (FEM) or a strip method such as the Equivalent Frame Method (EFM) or the Simple Frame Method (SFM) [Aalami, Kelley, 2001b].

**Figure 2.2.1-3** outlines the treatment of a typical design strip, such as B, when using a strip method. Observe that for design, the extracted strip B is idealized as shown in part (c) of the figure. **Figure 2.2.1-4** shows the span lengths L, and dimensional parameters, “a” through “f”, required for the calculation of minimum reinforcement for typical conditions.

**Figure 2.2.1-5** shows the geometrical parameters for the computation of minimum reinforcement and strength design of column line 3 of design strip B. If the Finite Element Method is used, the design strips do not need to be extracted from the floor system and treated in isolation. Hence, the idealization required for the strip methods would not apply.

#### A. At the Supports

A minimum area of bonded reinforcement must be provided at the supports, regardless of the service load stress condition. The area of this minimum reinforcement is a function of the geometry of the slab and the support layout.

The Code expression is:

$$A_s = 0.00075A_{cf} \quad (2.2.1-1)$$

Where,

- $A_s$  = area of reinforcement, and
- $A_{cf}$  = larger gross cross-sectional area of the design strips of the two orthogonal directions intersecting at the support under consideration. This is used as a “reference” area for minimum reinforcement calculation.

The area  $A_s$  is calculated separately for each of the two orthogonal directions at a support. The largest of the two values is selected for the support. Hence, the area of minimum rebar will be the same in both directions. The following explains the application of the Code relationship (2.2.1-1) to practical conditions. **Figures 2.2.1-4** through **2.2.1-6** are used to illustrate the procedure.

**Figure 2.2.1-4a** shows a column support (O) at the intersection of two orthogonal design strips, one in direction of analysis and the other normal to it. For this simple geometry, where the area  $A_{cf}$  in direction of frame being analyze is the line FF times the slab thickness. The area  $A_{cf}$  in the perpendicular direction is the line PP multiplied by the thickness of the slab. In the general case, such as the example shown in part (b) of the figure, the geometry of the idealized design strip is not necessarily simple. In direction of the frame, line OA and OB together with slab thicknesses at point A and B are used. Likewise, for the perpendicular direction, lines OC and OD with thicknesses at C and D are used.

The computation is explained in greater detail in the following. **Figure 2.2.1-5** shows an idealized design strip for use with ei-

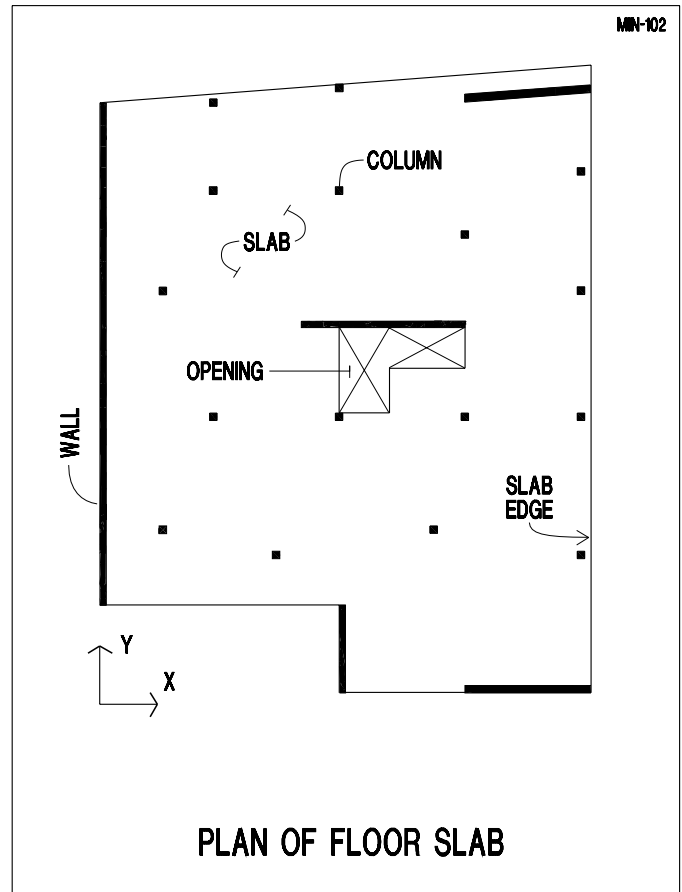

**FIGURE 2.2.1-1**

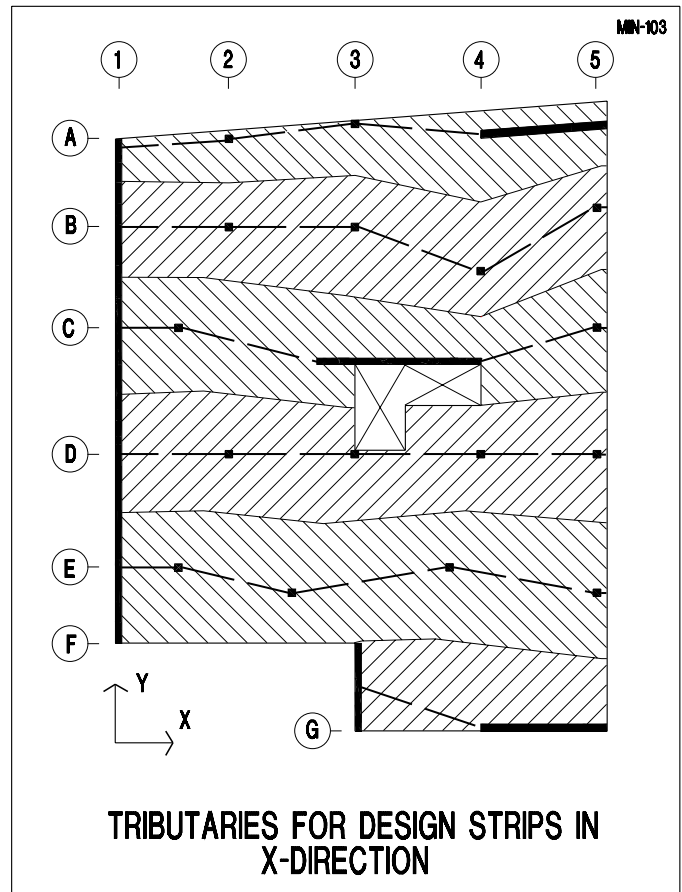

**FIGURE 2.2.1-2**

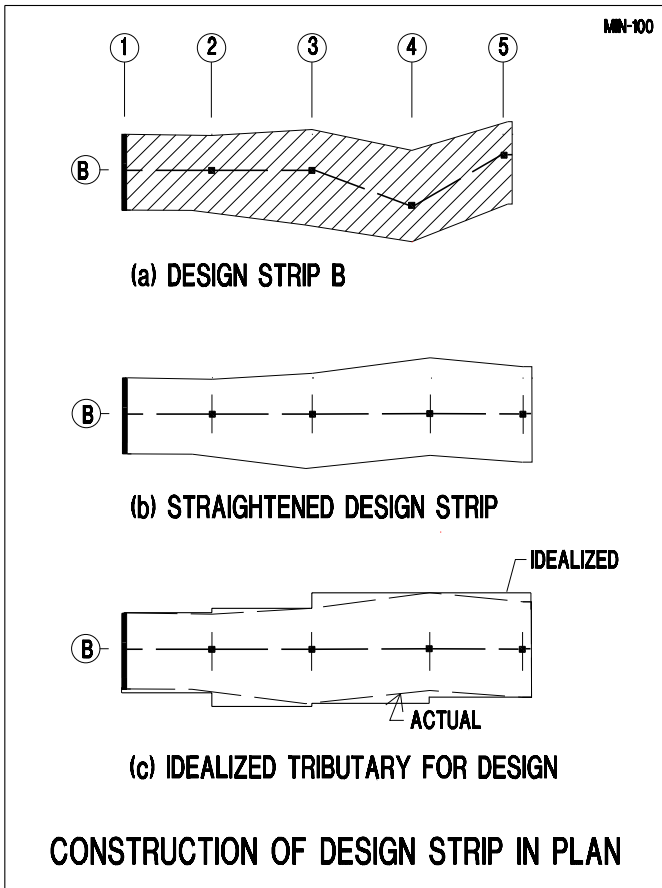

FIGURE 2.2.1-3

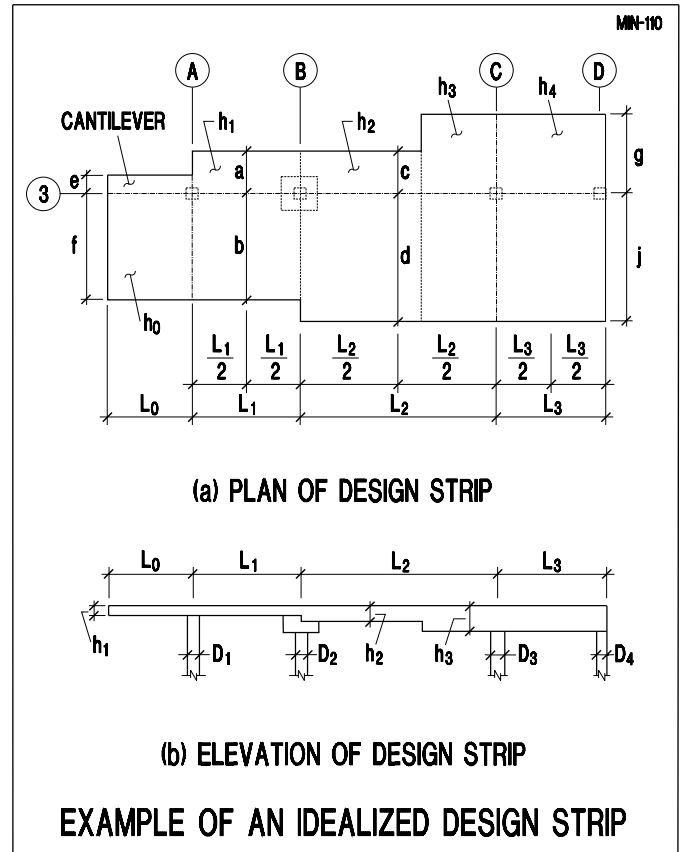

FIGURE 2.2.1-5

ther the Simple Frame Method (SFM), or the Equivalent Frame Method (EFM). A similar frame is illustrated in Fig. 2.2.1-6 for use with the Finite Element Method (FEM).

(i) For an interior support (Fig. 2.2.1-5, Gridline 3)

In the direction of the frame along gridline 3, the reference area used is:

$$A_{cf} = 0.5 * L_1 * h_1 + 0.5 * L_2 * h_2 \quad (2.2.1-2)$$

In the transverse direction (the direction normal to the frame being analyzed; normal to gridline 3), the areas on either side of the support are calculated:

$$A_{cf} = 0.5 (a * h_1 + c * h_2) + 0.5 (b * h_1 + d * h_2) \quad (2.2.1-3)$$

$A_{cf}$  is the larger of the two values.

(ii) For an exterior support without a cantilever (Gridline D)

In direction of the frame:

$$A_{cf} = 0.5 * L_3 * h_4$$

In direction normal to the frame

$$A_{cf} = g * h_4 + j * h_4 \quad (2.2.1-4)$$

$A_{cf}$  is the larger of the two values.

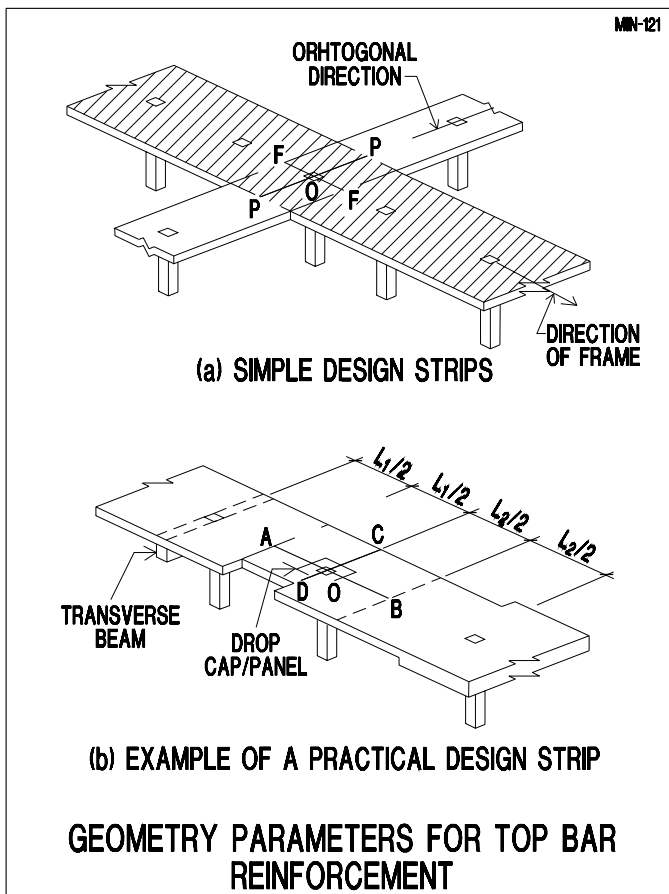

FIGURE 2.2.1-4

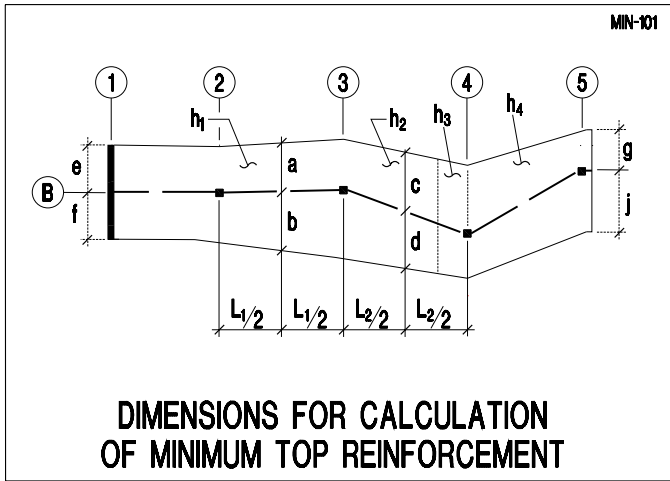

FIGURE 2.2.1-6

(iii) For an exterior support with a cantilever (Gridline A)

In direction of the frame:

$$A_{cr} = L_0 * h_0 + 0.5 * L_1 * h_1 \quad (2.2.1-5)$$

In the transverse direction:

$$A_{cr} = 0.5(e * h_0 + a * h_1) + 0.5(f * h_0 + b * h_1)$$

$$A_{cr} = \text{larger of the two values.}$$

(iv) Treatment of slab bands

A slab band (wide shallow beam) is a thickening of slab along the column line to allow additional tendon drape. The band dimensions must be such that the two-way characteristics of the floor system are retained. **Figure 2.2.1-7** shows the dimensional restrictions that are commonly used. In design strips where there are slab bands, reinforcement calculations should be based on an equivalent uniform slab thickness ( $h_e$ ).

$$h_e = [t * a + b(h-t)]/a \quad (2.2.1-6)$$

(v) Drop caps, drop panels, and transverse beams

Provision of drop caps and drop panels does not change the amount and length of the minimum bonded reinforcement. Beams

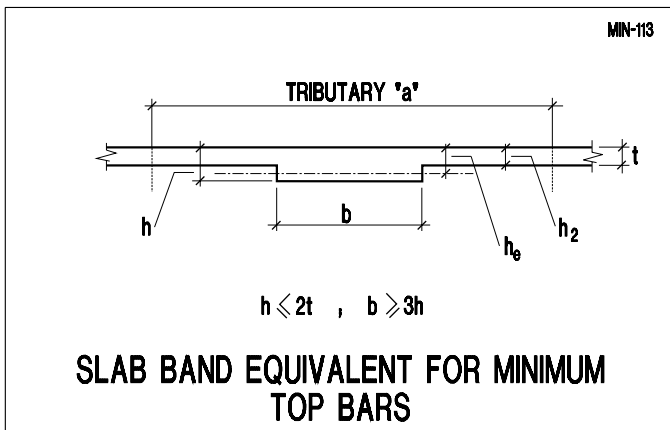

FIGURE 2.2.1-7

transverse to the direction of the analysis are not included in the calculation of the minimum bonded reinforcement.

### B. In the Span

Bonded reinforcement must be added where computed tensile stresses in the span exceed  $2(\sqrt{f'_c})$  [ $0.167\sqrt{f'_c}$ ]. The minimum area of bonded reinforcement is:

$$A_s = N_c / (0.5 * f_y) \quad (2.2.1-7)$$

In order to limit crack widths, the value used for  $f_y$  cannot be more than 60,000 psi (414 MPa).

$N_c$  is the force of the tensile stress block over the tributary of the design strip (**Fig. 2.2.1-8**). The stress distribution shown is calculated by applying the total actions on the tributary (the integral of the moment and axial force) to the entire cross-sectional area of the tributary.

### 2.2.2 Minimum Bonded Reinforcement for One-way Systems

The minimum bonded reinforcement in one-way slabs and beams is a function of the cross-sectional geometry of the member. It is independent of the loading, service stresses, and span length. Unlike two-way systems, where it is possible to design a floor with no bottom rebar, the Code requires bonded reinforcement over the supports and at the bottom of the slab in the span of all unbonded one-way systems. The required steel  $A_s$  is:

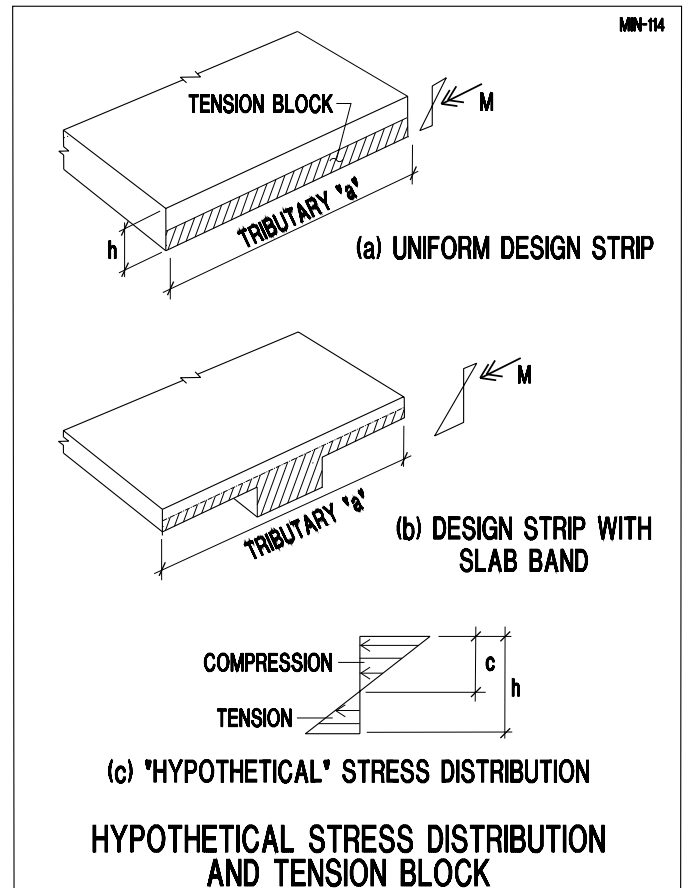

FIGURE 2.2.1-8

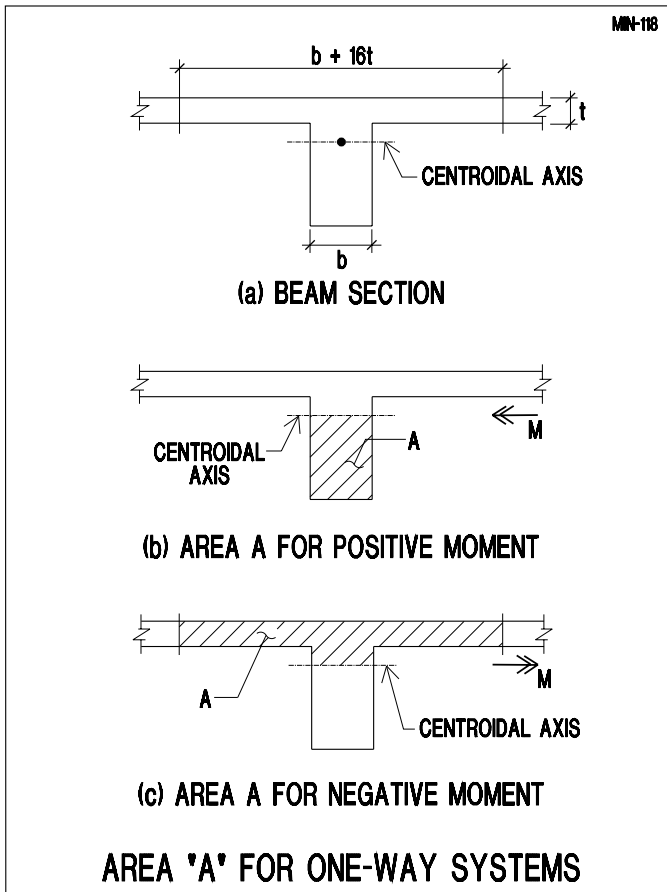

FIGURE 2.2.2-1

$$A_s = 0.004A \quad (2.2.2-1)$$

Where,

A = area of that part of cross-section between the flexural tension face and the center of gravity of the gross section.

Figure 2.2.2-1 illustrates the area “A” for the positive and negative moments. The Code specifies the effective width in bending of nonprestressed members as the stem plus eight times the flange thickness on each side. However, for prestressed members under axial load and bending, the Code does not specify an effective width. The effective flange width to be used for the calculation of minimum bonded reinforcement in a prestressed member is recommended to be the same as if the beam were non-prestressed. This is typically the stem width plus eight times the slab thickness on each side. Since cracking under service conditions is a flexural phenomenon, the effective width associated with flexure applies.

It is important to note that for consistency, the effective width assumed for minimum reinforcement calculation should be the same as used for the computation of flexural stresses in other stages of design.

### 2.2.3 Length of Minimum Bonded Reinforcement

The bonded reinforcement in positive moment areas should be at least one-third of the clear span length and should be centered

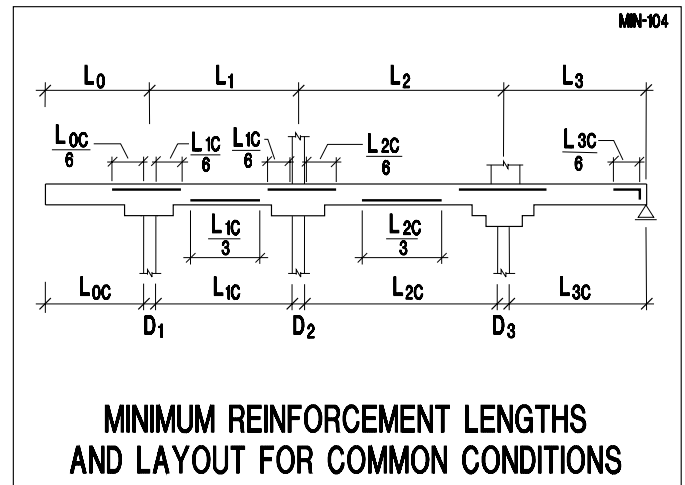

FIGURE 2.2.3-1

in the positive moment area. The bonded reinforcement in negative moment areas should extend one-sixth the clear span on either side of the support. These lengths, shown schematically in Fig. 2.2.3-1, apply when bonded reinforcement is not required for flexural strength. It is not necessary to add development lengths to the lengths shown.

### 2.2.4 Layout of Minimum Bonded Reinforcement

#### A. Two-way System

Top bars must be placed within a narrow band over the support that is equal to the support width plus one and one-half times the depth of the slab/cap on each side, as indicated in Fig. 2.2.4-1. Figure 2.2.4-2 illustrates the staggering of bars for improved performance.

The positioning of the bottom bars is governed by the layout of tendons. In a banded system, bonded reinforcement in the banded direction is typically placed within the band width, while in the distributed direction it is spread uniformly over the tributary of the design strip.

#### B. One-way System

The top and bottom bars in one-way systems are both distributed evenly over the width of the slab. The bottom bars for the beams are placed within the stem of the beam. The top bars should be placed within the width of the beam if practical. If this is not practical, they can be placed within the reinforcement strip defined in Fig. 2.2.4-1, where column width is replaced by stem width.

### 2.3 All Post-Tensioning Systems

The following requirements apply to both unbonded and bonded systems.

#### 2.3.1 Shrinkage and Temperature Reinforcing

Temperature and shrinkage reinforcement is required in regions where the average precompression is less than 100 psi ( 0.70 MPa). Since floor systems designed according to Code should have a minimum of 125 psi (0.85 MPa) precompression, the requirement of temperature and shrinkage reinforcement is implicit.

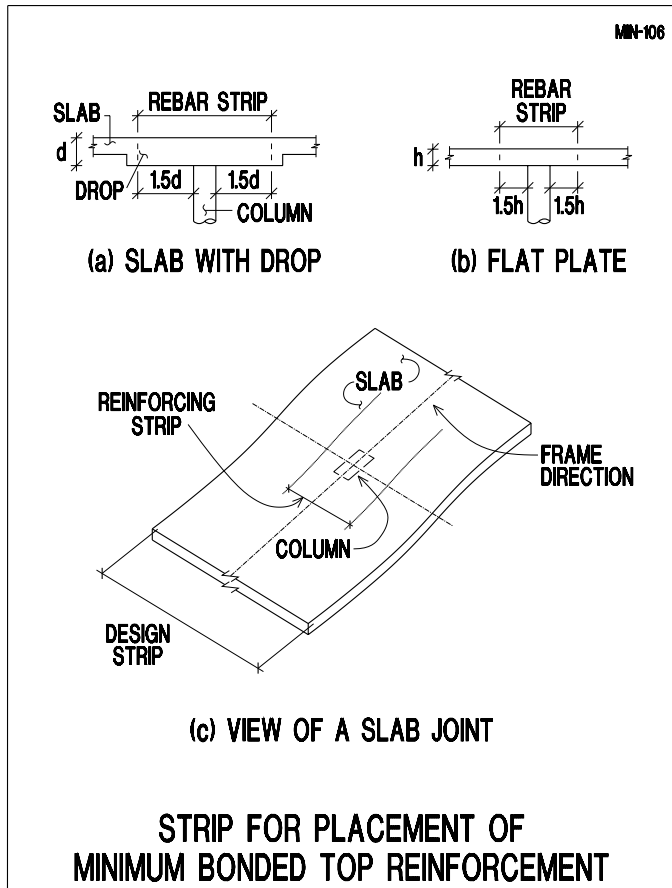

**FIGURE 2.2.4-1**

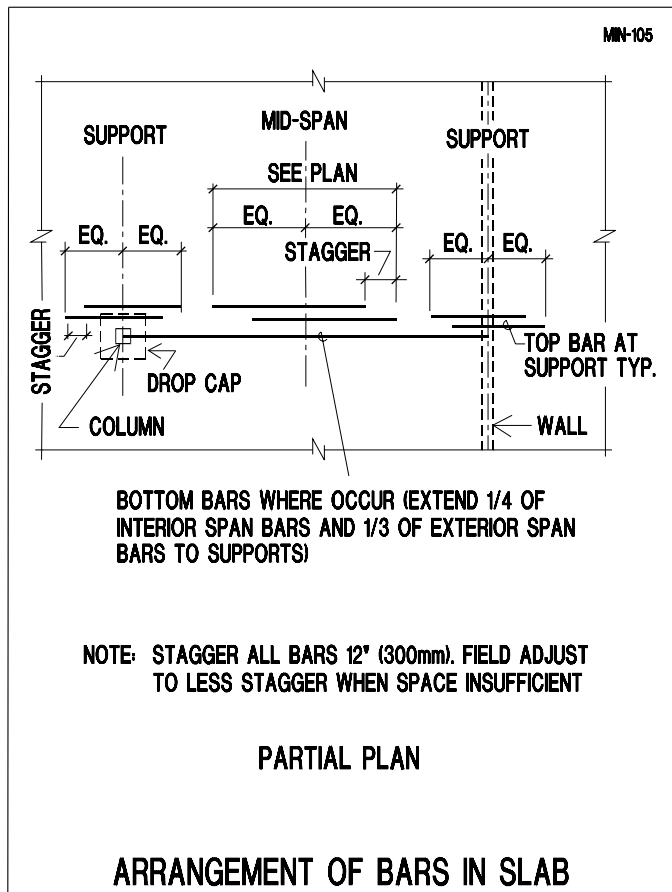

**FIGURE 2.2.4-2**

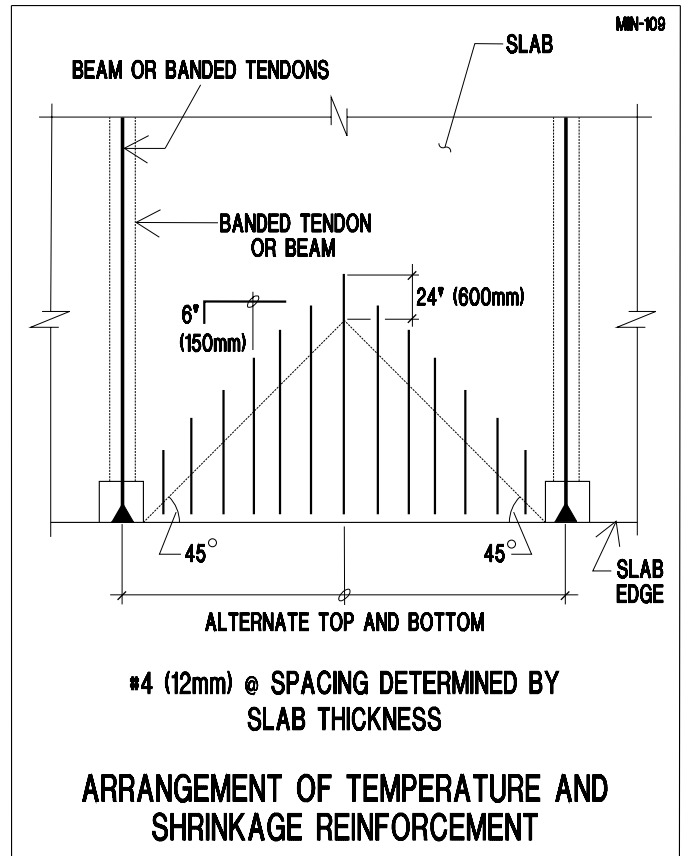

**FIGURE 2.3.1-1**

itly satisfied. However, bonded reinforcement or additional tendons must be provided where the local average precompression within the tributary of a post-tensioned member falls below 100 psi (0.70 MPa). An example of this is the wedge-shaped region at the slab edge between two adjacent beams or tendon bands, as illustrated in Fig. 2.3.1-1 [Aalami, 1993a]. The reinforcement requirement for this region is either prestressing that provides 100 psi (0.70 MPa) average precompression (Fig. 2.3.1-2), or bonded reinforcement equal to 0.0018 times the area of the slab, or a combination of the two. The requirement is expressed by:

In American units:

$$(P/A)/100 + A_s/(0.0018 \cdot A) \geq 1 \quad (2.3.1-1)$$

In SI units:

$$(P/A)/0.70 + A_s/(0.0018 \cdot A) \geq 1 \quad (2.3.1-2)$$

Where,

- A = is the gross cross-sectional area to being reinforced for shrinkage and temperature,
- A<sub>s</sub> = area of bonded reinforcement provided, and
- P = prestressing force provided for temperature and shrinkage

When using American units, P/A is expressed as psi. When using SI units, P/A is expressed as MPa.

Tendons used for shrinkage and temperature reinforcement should not be spaced more than 6 ft (1800 mm) apart. This maximum spacing does not apply to the tendons used for primary reinforcement. There is no maximum spacing for banded tendons, pro-

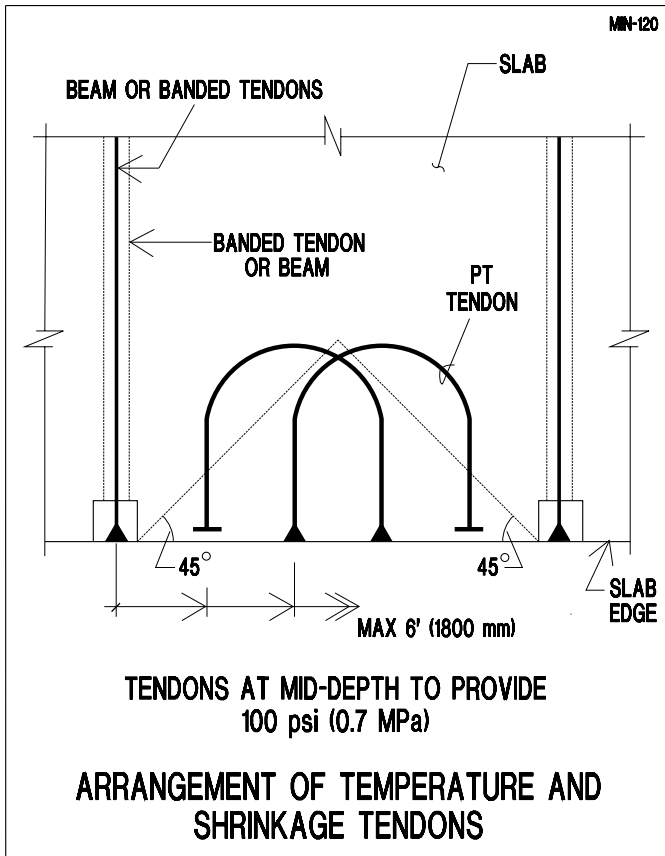

FIGURE 2.3.1-2

vided the tendons in the orthogonal direction are not spaced farther than 8 times the slab thickness, or 48 in. (1220 mm). Tendon spacing and layout is discussed in reference [Aalami, 2000].

The wedge shaped area can be reinforced using either bonded reinforcement as shown in Fig. 2.3.1-1, or looped prestressing tendons (Fig. 2.3.1-2).

When using tendons for temperature and shrinkage, the tendons should be placed at mid-depth of the slab section. These tendons need not be extended beyond the wedge shaped area in the slab. The extension of these tendons much beyond the wedge shaped area will result in a reduction of the design eccentricity of the post-tensioning away from the supports. This is more pronounced in one way slab and beam construction, if temperature tendons are placed above the combined centroid of the beam and slab section.

### 2.3.2 Diaphragm Action of Floor Systems Under Seismic and Wind Loading

Post-tensioned floors act as diaphragms in distributing the seismic or wind loading among the lateral load resisting system of the building. In this capacity, post-tensioned floors are designed to remain elastic. They are not expected to participate in the energy dissipation of the building during seismic events. For non-energy dissipating diaphragms, the Code requires a minimum reinforcement equal to that specified for temperature and shrinkage.

Since the Code places a more stringent requirement for the gravity design of post-tensioned floors (minimum of 125 psi (0.85 MPa)), the diaphragm requirement of 100 psi (0.70 MPa) precompression is automatically satisfied. Locations such as the wedge-shaped regions shown in Fig. 2.3.1-1 will be an exception. These wedge-shaped regions will satisfy the diaphragm requirement of the Code when reinforced according to the relationship (2.3.1-1) or (2.3.1-2).

## 3 - STRUCTURAL DETAILING

Most designs require a number of practical approximations, both in the modeling of the structure and in its analysis. The analysis and design process thus determines the primary reinforcement for the structural model. The design engineer must review the results and account for any items that were not adequately addressed. The critical review of the structural documents at this stage, and the addition or modification of reinforcement obtained from the first stage of the design, is referred to as "Structural Detailing".

### 3.1 Completion of Load Path

Determination of the principal reinforcement of a floor system requires:

- (i) selection of a load path by the design engineer,
- (ii) calculation of the demand actions (moments, shears, axial forces) for the selected load path,

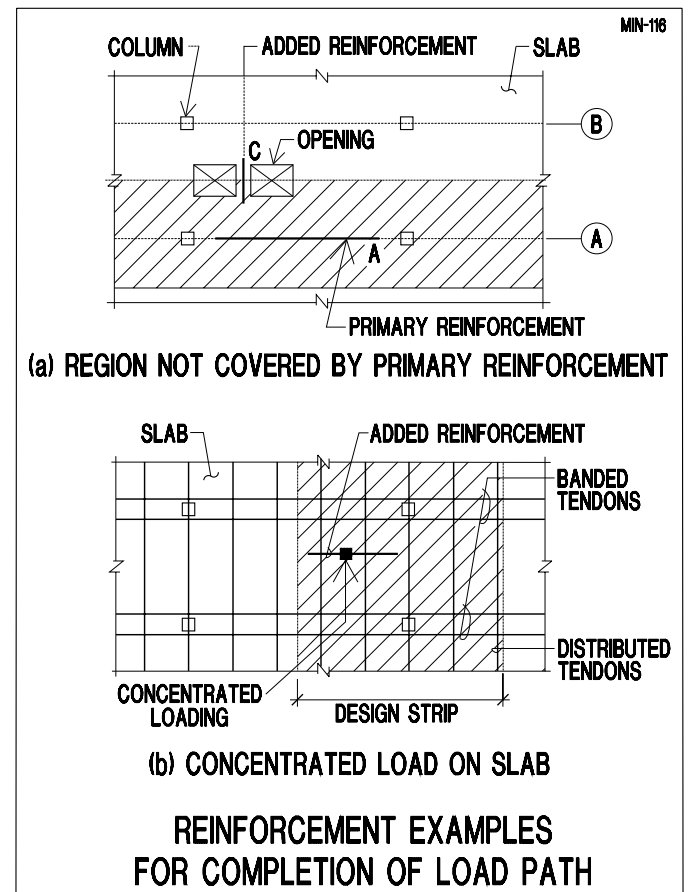

FIGURE 3.1-1

(iii) calculation of the required reinforcement.

The overall load paths of the floor system are selected on the basis of the support lines and their associated design strips. This is the procedure for the Finite Element Method as well as strip methods of analysis such as the Equivalent Frame Method (EFM). The load path selected for the primary reinforcement does not always account for the details of the floor system. Areas that are not adequately treated through the structural model for the overall analysis need to be identified and reinforced by the design engineer.

As an example, consider **Fig. 3.1-1a**. The design strip A will give the reinforcement ( $A_s$ ) along column line A. As part of the Structural Detailing, the strip of concrete (C) between the two openings shall be designed and detailed to transfer its load to the design strips A and B using nonprestressed reinforcement. There are many instances like this where additional reinforcement is required for completion of the load paths. The minimum amount of reinforcement for such regions is that given in section 2.3-1 for shrinkage and temperature. Another example of Structural Detailing is the addition of nonprestressed reinforcement or the relocation of tendons below concentrated loads (**Fig. 3.1-1b**).

### 3.2 Crack Control at Discontinuities

At discontinuities such as reentrant corners and openings (**Fig. 3.2-1**), bonded reinforcement should be added to control the width of cracks that are likely to occur. The amount and length of the

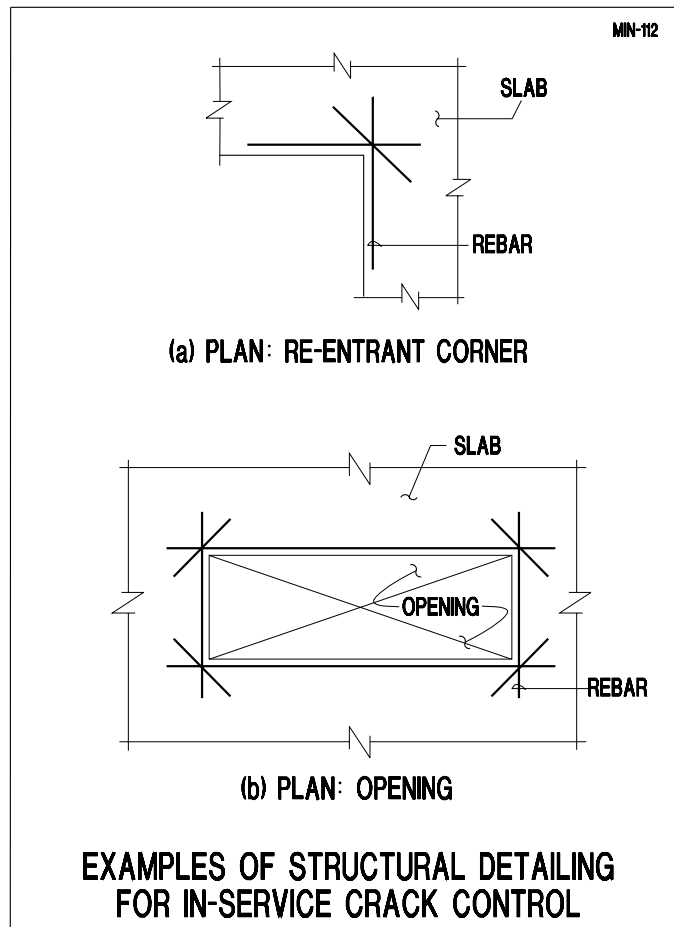

FIGURE 3.2-1

reinforcement will depend on the geometry of the region adjacent to the discontinuity.

### 3.3 Crack Mitigation Due to Restraint of Supports

Post-tensioned floors shorten due to the combined effects of elastic shortening, drying shrinkage, creep, and temperature changes. If the supports are not designed to accommodate this shortening, visible cracks will form. A detailed discussion of mitigation of cracking due to support restraint is given in reference [Aalami, Barth 1988].

Restraint from the supports is most critical at the lowest floor levels of the structure. In common construction, the practice is to either allow for the shortening of the lower level floors by temporary or permanent releases at the supports, or to provide bonded reinforcement to control the crack widths. Both practices are based on empirical guidelines [Aalami, Barth, 1988].

**Figure 3.3-1** shows the bonded reinforcement added for crack control adjacent to a shear wall. The detail is typically only used for the first three levels of a structure. In most cases, at the fourth level and above, no reinforcement is added for support restraint.

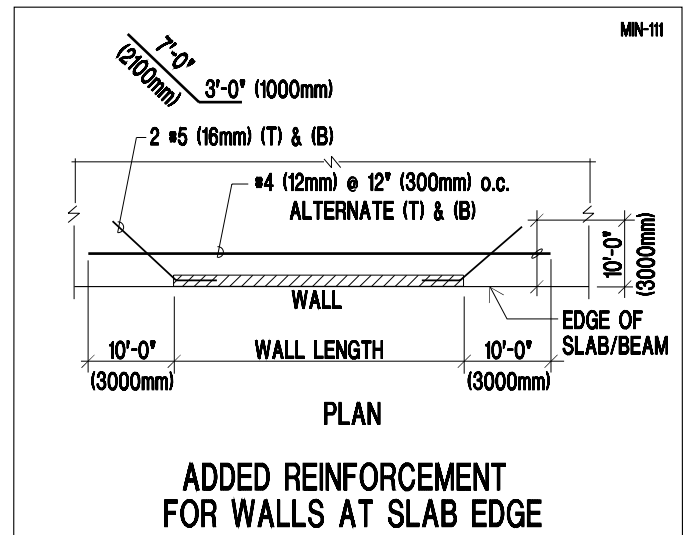

FIGURE 3.3-1

### 3.4 Reinforcement Behind Anchorage Devices

Bonded reinforcement is added behind the anchorage devices to avoid concrete "blowouts" and cracking due to the splitting tensile stresses normal to the direction of the prestressing [PTI, 2000]. **Figure 3.4-1a** shows the reinforcement for anchorage devices grouped together in the banded tendon direction. **Figure 3.4-1b** shows the reinforcement for the anchorage devices of tendons in the distributed direction. **Figure 3.4-2** is an end view of the anchorage devices for tendons in the banded direction. Note that the anchorage devices shown are grouped in bundles of maximum four.



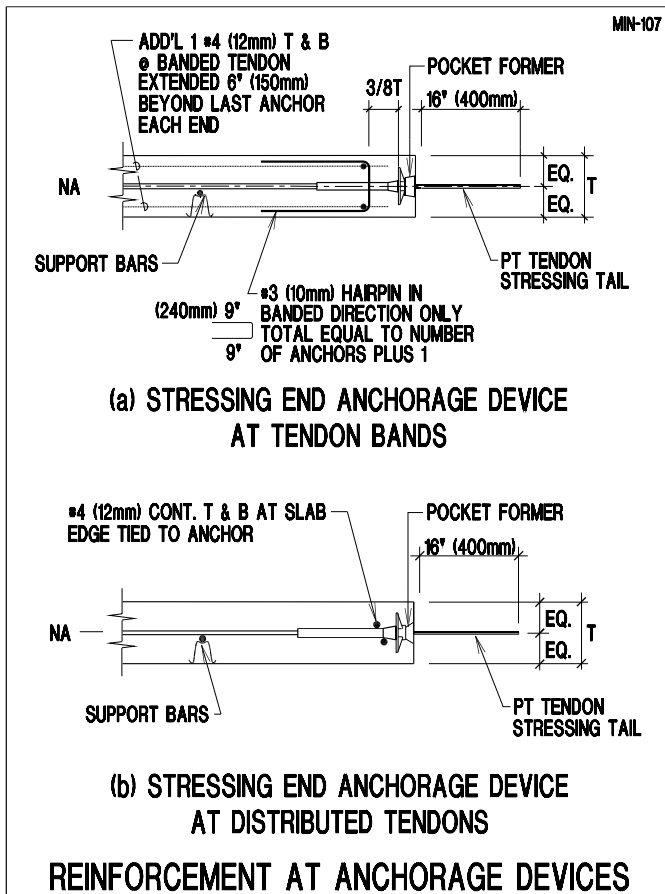

FIGURE 3.4-1

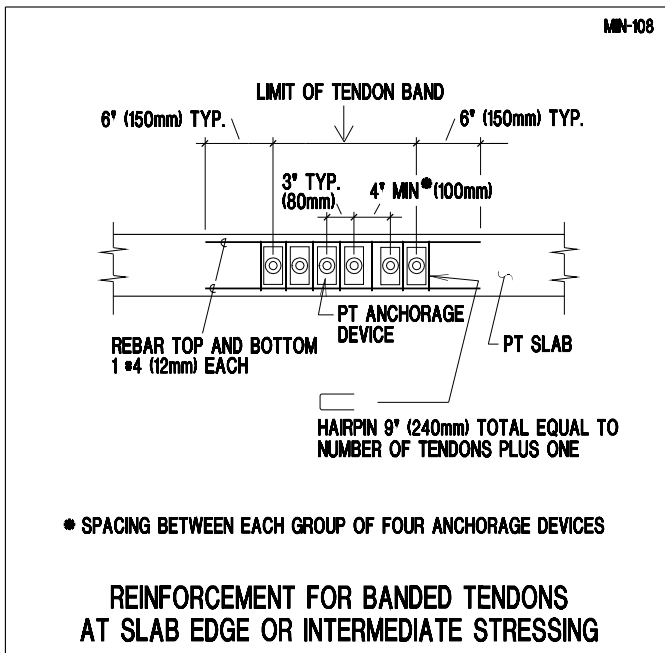

FIGURE 3.4-2

#### 4 - CONSTRUCTION REQUIREMENTS – INSTALLATION DRAWINGS

Bonded reinforcement along with chairs is typically used to secure the tendons in position and ensure that the profiles are maintained during placement and consolidation of the concrete. The support bar provide horizontal resistance to displacement and

the chair positions the tendon vertically in the slab. The support bars necessary for positioning and securing the tendons are shown on the installation drawings. Preparation of installation drawings is not covered in this Technical Note. Although the support bars will likely have a beneficial effect on the slab as far as crack control, they are typically not taken into account in any structural calculations. Nonprestressed reinforcement used as temperature and shrinkage reinforcing in one-way slabs may be used as tendon supports.

#### 5 - NUMERICAL EXAMPLES

The following examples illustrate the application of several of the requirements to practical problems.

##### 5.1 Minimum Reinforcement for an Unbonded Two-Way Floor System

Consider the idealized design strip of a two-way floor system as shown in Fig. 2.2.1-4 with the following dimensions.

Span Lengths:

$L_0$	= 10 ft	(3048 mm)
$L_1$	= 17 ft	(5182 mm)
$L_2$	= 32 ft	(9754 mm)
$L_3$	= 10 ft	(3048 mm)

Slab Thickness:

$h_0$	= 6 in.	(153 mm)
$h_1$	= 6 in.	(153 mm)
$h_2$	= 8.5 in.	(216 mm)
$h_3$	= 10 in.	(254 mm)

Tributary Widths:

a	= 10 ft	(3048 mm)
b	= 15 ft	(4572 mm)
c	= 10 ft	(3048 mm)
d	= 17 ft	(5182 mm)
e	= 4 ft	(1220 mm)
f	= 15 ft	(4572 mm)
g	= 14 ft	(4268 mm)
j	= 17 ft	(5182 mm)

Column Dimensions (all columns are square):

$D_1$	= 18 in.	(458 mm)
$D_2$	= 20 in.	(508 mm)
$D_3$	= 26 in.	(661 mm)
$D_4$	= 18 in.	(458 mm)

##### 5.1.1 Minimum Bonded Reinforcement Over Interior Support At Line B

In direction of frame:

$$A_{cf} = 0.5 * 17 * 12 * 6 + 0.5 * 32 * 12 * 8.5 = 2244 \text{ in}^2 (1447739 \text{ mm}^2)$$

In direction transverse to the frame:

$$A_{cf} = 0.5*(10*12*6 + 10*12*8.5) + 0.5*(15*12*6 + 17*12*8.5)$$

$$= 2277 \text{ in}^2 (1469029 \text{ mm}^2)$$

Select:  $A_{cf} = 2277 \text{ in}^2$

$$A_s = 0.00075*2277$$

$$= 1.71 \text{ in}^2 (11.02 \text{ cm}^2)$$

Use 6 #5 →  $A_s$  provided =  $1.86 \text{ in}^2 > 1.71 \text{ in}^2$  OK  
 (Use 6 Ø16 mm →  $A_s$  provided =  $12.05 \text{ cm}^2 > 11.02 \text{ cm}^2$  OK)

Calculate required bar length:

In the direction of the frame:

Clear spans:

$$L_{1c} = 17*12 - 0.5(18 + 20) = 185 \text{ in} (4700 \text{ mm})$$

$$L_{2c} = 32*12 - 0.5(20 + 26) = 361 \text{ in} (9170 \text{ mm})$$

$$L = 20 + (185 + 361)/6 = 111 \text{ in} (2820 \text{ mm})$$

Select 9' - 6" (3000 mm = 3 m)

This is the minimum length required by the Code. It is recommended to use a greater length which would allow the bars to be centered over the column.

Place the reinforcement within a band over the support not wider than

$$20 + 1.5(6 + 8.5) = 41.75 \text{ in} (1067 \text{ mm})$$

say 42 in.(1067 mm, say 1100 mm).

Other Code requirements are that there must be a minimum of four bars over the support and the spacing between the bars must not exceed 12 inches (300 mm). The bars selected for this example will automatically satisfy these requirements.

### 5.1.2 Minimum Bonded Reinforcement in Span BC

In the span, bonded reinforcement is required where the computed (hypothetical) tensile stresses exceed the allowable limit of  $2(\sqrt{f'_c})$ .

At a point 9 ft (2.75 m) from the face of support of column B, the computed total (integrated) actions over the tributary of the design strip are:

$$M_d = 230 \text{ k-ft} (312 \text{ kNm}) \text{ Dead load moment}$$

$$M_l = 125 \text{ k-ft} (170 \text{ kNm}) \text{ Live load moment}$$

$$M_{pt} = -195 \text{ k-ft} (-265 \text{ kNm}) \text{ Post-tensioning moment}$$

$$P = 375 \text{ k} (1670 \text{ kN})$$

Post-tensioning force

The tributary width is 27 ft (8.28 m) and the specified concrete strength  $f'_c = 5000 \text{ psi} (34.5 \text{ MPa})$

Calculate the hypothetical tension stress:

Section properties:

Area:  $A = 27*12*8.5$   
 $= 2754 \text{ in}^2 (1776770 \text{ mm}^2)$

Moment of inertia:

$$I = (27*12)^3*8.5^3/12$$

$$= 16581.38 \text{ in}^4 (690170 \text{ cm}^4)$$

$$Y_t = Y_b = 8.5/2$$

$$= 4.25 \text{ in} (108 \text{ mm})$$

Section modulus:

$$S = 16581.38/4.25$$

$$= 3901.5 \text{ in}^3 (63934 \text{ cm}^3)$$

Stress at bottom:

$$f = (M_d + M_l + M_{pt})/S - P/A$$

$$= (230 + 125 - 195)*12000/3901.5 - 375000/2754$$

$$= 492.12 - 136.17$$

$$= 355.95 \text{ psi} (2.45 \text{ MPa})$$

Stress threshold =  $2(\sqrt{f'_c}) = 2\sqrt{5000}$   
 $= 141.42 \text{ psi} (0.98 \text{ MPa})$

$f = 355.95 \text{ psi} > 141.42 \text{ psi}$ , hence bonded reinforcement is required.

Calculate the tension force  $N_c$ :

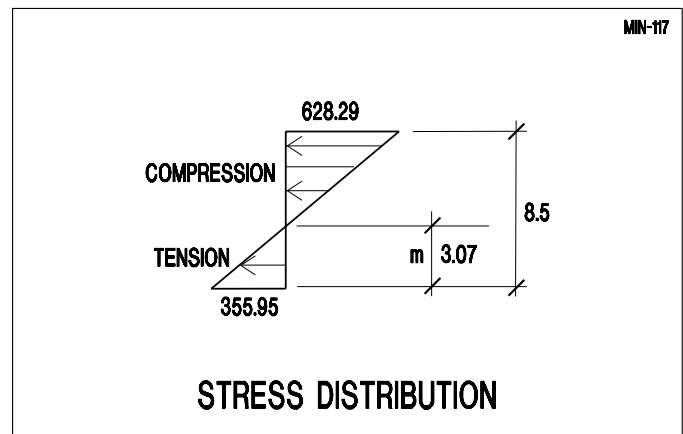

FIGURE 5.1.2-1

Stress in compression (Fig. 5.1.2-1):

$$f = (M_d + M_l + M_{pt})/S - P/A$$

$$= -492.12 - 136.17$$

$$= -628.29 \text{ psi} (-4.33 \text{ MPa})$$

The depth of the tension zone,  $m$ , is:

$$m = [355.95 / (355.95 + 628.29)] * 8.5 = 3.07 \text{ in. (78 mm)}$$

$$N_c = 0.5 * 355.95 (3.07 * 27 * 12) = 177028 \text{ lb (787.44 kN)}$$

Calculate the area of reinforcement required:

$$A_s = 177028 / (0.5 * 60000) = 5.90 \text{ in}^2 (38.07 \text{ cm}^2)$$

Use 20 #5  $\rightarrow 20 * 0.31 = 6.20 > 5.90 \text{ in}^2$  OK  
 (Use 19  $\varnothing 16\text{mm} \rightarrow 19 * 2.01 = 38.19 \text{ cm}^2 > 38.07 \text{ cm}^2$  OK)

Note that at other locations in the span, the actions will be different and the amount of bonded reinforcement required might be different from what is calculated above. Bar selection should be based on the largest calculated requirement.

Calculate the bar length:

$$\begin{aligned} \text{Bar length} &= L_{2c} / 3 = 361 / 3 \\ &= 120.33 \text{ in. (3057 mm)} \\ \text{Select: } &20 \text{ \#5 } \times 10' - 6'' \quad (20 \varnothing 16\text{mm} \times 3100 \text{ mm}) \end{aligned}$$

## 5.2 Minimum Reinforcement for a One-Way System

For the one-way beam and slab construction shown in **Fig. 5.2-1**, calculate the required minimum top and bottom reinforcement for the beam.

Define the geometry of the beam cross-section and find its centroid.

$$\text{Effective width } b_e = 2 * 8 * 5 + 14 = 94 \text{ in. (2390 mm)}$$

For the effective width of 94 in., the centroid is 21.10 in. (536 mm) from the bottom of the beam.

Minimum reinforcement for the span

$$\begin{aligned} \text{Area on the tension side:} \\ A &= 14 * 21.10 = 295.40 \text{ in}^2 (1905.80 \text{ cm}^2) \end{aligned}$$

Minimum bar area  $A_{min}$ :

$$\begin{aligned} A_{min} &= 0.004 * 295.40 = 1.18 \text{ in}^2 (7.62 \text{ cm}^2) \\ \text{Use 2 \#7 bars} &\rightarrow 2 * 0.60 = 1.20 \text{ OK} \\ \text{(Use 3 } \varnothing 18 &\rightarrow 3 * 2.54 = 7.61 \text{ cm}^2 \text{ OK)} \end{aligned}$$

$$\text{Length} = (65 - 2) / 3 = 21 \text{ ft (6500 mm)}$$

Minimum reinforcement over the support

$$\begin{aligned} \text{Area on the tension side:} \\ A &= 94 * 5 + 14(8.90 - 5) = 524.60 \text{ in}^2 (3385 \text{ cm}^2) \end{aligned}$$

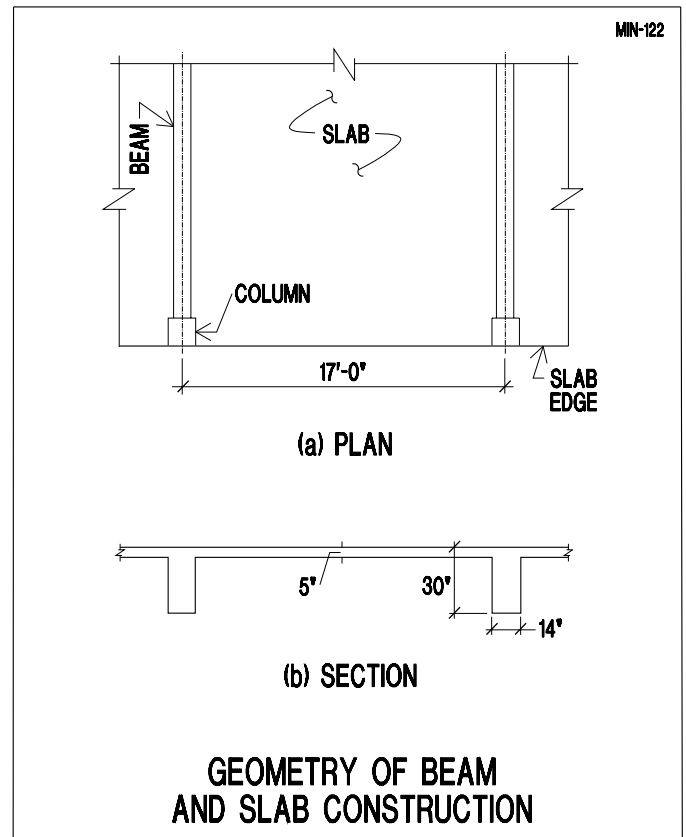

FIGURE 5.2-1

Minimum bar area  $A_{min}$ :

$$\begin{aligned} A_{min} &= 0.004 * 524.60 = 2.10 \text{ in}^2 (13.55 \text{ cm}^2) \\ \text{Use 4 \#7 bars} &\rightarrow 4 * 0.60 = 2.40 \text{ in}^2 \text{ OK} \\ \text{(Use 4 } \varnothing 22 &\rightarrow 4 * 3.80 = 15.20 \text{ cm}^2 \text{ OK)} \end{aligned}$$

$$\text{Length} = (65 - 2) / 6 = 10.5 \text{ ft (3200 mm)}$$

## 5.3 Reinforcement for Shrinkage and Temperature

Determine the Code required reinforcement for the slab wedge between the beams of the one-way slab and beam construction shown in **Fig. 5.2-1**.

Either bonded reinforcement or prestressing can be used.

### A. Bonded reinforcement

$$A_{min} = 0.0018 * 5 * 12 = 0.108 \text{ in}^2/\text{ft} \quad (2.29 \text{ cm}^2/\text{m})$$

$$\begin{aligned} \text{Use \#4 @ 18'' o.c.} &\rightarrow A_s (\text{provided}) = 0.13 > 0.108 \\ \text{in}^2/\text{ft} &\text{ OK} \\ \text{(Use } \varnothing 12 \text{ mm @ 40 cm)} &\rightarrow A_s (\text{provided}) = 2.83 > 2.29 \text{ cm}^2/\text{m} \text{ OK} \end{aligned}$$

Alternate bars at the top and bottom of the slab.

Extend bars 24 in. (600 mm) beyond the 45 degree wedge at the slab edge.

Place bars within the wedge shaped area shown in **Fig. 2.3.1-1**.

## B. Use additional 0.5 inch (12mm) tendons.

Alternatively, unbonded tendons are used at one third points of the slab span to provide an average precompression of 100 psi (0.7 MPa) over the wedge shaped region at slab edge.

Assume effective force of each strand = 26.8 k (119.2 kN)

Maximum cross-sectional area needing reinforcement:

$$\begin{aligned} A &= (17 \times 12 - 14) \times 5 \\ &= 950 \text{ in}^2 \quad (612902 \text{ mm}^2) \end{aligned}$$

Provide two looped and staggered tendons as shown in **Fig. 2.3.1-1**. Extend the loop by  $0.5 \times 17 = 8.5 \text{ ft}$  (2.60m).

## 6 - REFERENCES

Aalami, B. O. and Barth, F. G. (1988) “*Restraint Cracks and Their Mitigation in Unbonded Post-Tensioned Building Structures*,” Post-Tensioning Institute, Phoenix, AZ, 49 pp.

Aalami, B. O. (1989). “*Design of Post-Tensioned Floor Slabs*,” Concrete International, ACI, June 1989, Vol. 11, No. 6, pp 59-67.

Aalami, B. O. (1990). “*Load Balancing – A Comprehensive Solution to Post-Tensioning*,” ACI Structural Journal, V. 87, No. 6, November/December, 1990, pp. 662-670.

Aalami, B.O. (1993a). “*Effective Width and Post-Tensioning*,” PTI Technical Note #1, April 1993, Post-Tensioning Institute, Phoenix, AZ, 4 pp.

Aalami, B. O. (1993b). “*One-Way and Two-Way Post-Tensioned Floor Systems*,” PTI Technical Note #3, October, 1993, Post-Tensioning Institute, Phoenix, AZ, 10 pp.

Aalami, B. O. (1994). “*Unbonded and Bonded Post-Tensioning in Building Construction - A Design and Performance Review*,” PTI Technical Note #5, September, 1994, Post-Tensioning Institute, AZ, 10 pp.

Aalami, B. O. and Bommer, A. (1999) “*Design Fundamentals of Post-Tensioned Concrete Floors*,” Post-Tensioning Institute, Phoenix, AZ, pp. 406.

Aalami, B. O. (2000). “*Layout of Post-Tensioning and Passive Reinforcement in Floor Slabs Reinforcement in Post-Tensioned Floor Slabs*,” PTI Technical Note #8, Post-Tensioning Institute, Phoenix, AZ, April

Aalami, B. O., and Kelley, S. K., (2001a) “*Structural Design of Post-Tensioned Floors*,” Concrete International, American Concrete Institute, January 2001, pp. 31-36.

Aalami, B. O., and Kelley, G. S. (2001b) “*Design of Concrete Floors With Particular Reference to Post-Tensioning*,” PTI TN , Post-Tensioning Institute, Phoenix, AZ, January 2001.

ACI-423 (1996). “*Recommendations for Concrete Members Prestressed with Unbonded Tendons*,” ACI 423.3R-96, American Concrete Institute, Detroit, MI.

ACI-318 (1999). “*Building Code Requirements for Structural Concrete*,” American Concrete Institute, Detroit, MI, pp. 391

IBC2000, (2000) “*International Building Code*,” International Code Council, Inc., Falls Church, Va., 756 pp.

PTI (1990), *Post-Tensioning Manual*, 5<sup>th</sup> Edition, Post-Tensioning Institute, Phoenix, AZ, pp. 406.

PTI (2000), “*Field Procedures Manual for Unbonded Single Strand Tendons*,” Post-Tensioning Institute, Phoenix, AZ, 3<sup>rd</sup> edition, pp. 61.

ADPT\_Minbar.p65



POST-TENSIONING INSTITUTE  
Consulting Company Member



SOFTWARE FOR STRUCTURAL CONCRETE  
Dedicated to Design Professionals



AMERICAN SEGMENTAL BRIDGE INSTITUTE  
Organizational Member

This publication is intended for the use of professionals competent to evaluate the significance and limitations of its contents and who will accept responsibility for the application of the material it contains.

1733 Woodside Road, Suite 220, Redwood City, CA 94061, USA TEL 650.306.2400 FAX 650.364.4678 E-MAIL info@adaptsoft.com www.adaptsoft.com